

## SM82 Switch mode Range of Automatic Battery Chargers



### Description

The SM82 is a highly efficient high performance charger. The very smooth output is configured for accurate fast charging, optimum battery life and reliability. The charger is designed to cater for continuous float charging and standby battery applications. Due to its very smooth output (< 1% ripple) the charger is suitable for sealed or vented batteries. e.g. Nickel Cadmium (NiCd), Lead Acid sealed (VRLA), vented and plant cells.

Switch mode technology is a major advance in power supply and battery charger design. Giving low heat dissipation compact low weight design and ease of panel installation via din rail. Utilising the benefits of switch mode, the charger will give a constant current output up to its knee point (13 Volts on a 12 Volt LA) and then ramp down to its float voltage (see graph below). This gives an optimum charge time to ensure that the battery voltage is maintained at the pre-calibrated float level, whilst supplying any additional standing load current up to a specified maximum.

Charging current vs voltage

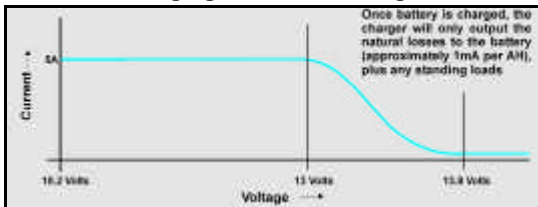

### Boost option

A 'boost' mode of operation provides increased voltage output. Selection of boost mode is via two terminals, allowing activation by a time delay relay or switch. A calibration table overleaf shows details of float and boost voltages.

### Charge fail option

A self diagnostic 'charge fail' circuit and relay output can be provided. The volt free relay de-energises in the event of a charging fault.

Electrical connection of the AC supply, DC output and charge fail relay are via shrouded screw terminals.

- High rate duty float charging: 5A @ 12VDC - 3A or 5A @ 24VDC output
- Fully automatic charge regulation
- Light compact DIN rail mount design
- Optional boost mode
- Optional charge fail relay output

### Product Specification

#### Power Supply:

nominal operating voltages	95-135VAC 195-277VAC
nominal operating frequency	47-400Hz

#### DC Charge Output:

output current ADC	5	5
nominal voltage VDC	24	12
line regulation	< 1%	
load regulation	< 1%	
output ripple	< 1%	
float / boost voltages	see table overleaf	

#### Charge Fail Output:

relay type	volt free SPDT contacts relay de-energised on fault
contact rating	1A @ 30VDC (resistive load)

#### General:

operating temperature	-10 to +55°C
overall dimensions (w x h x d)	133mm x 130mm x 80mm (5.2" x 5.1" x 3.2")
weight	0.56Kg (1.24lbs)
EMC emission / immunity	EN 58801-2 / EN50082-2

### Warranty

A one year limited warranty on materials and workmanship is given with this product. Details are available upon request.

## Electrical connection

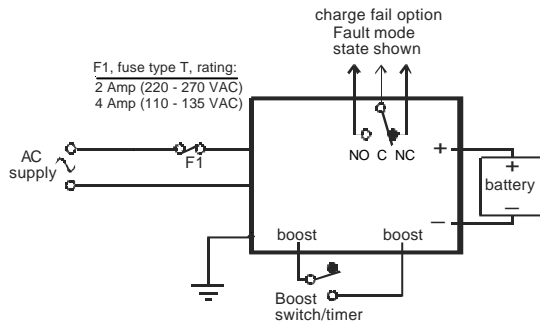

Notes:

- 1) battery output is isolated from chassis
- 2) chassis must be connected to a low impedance earth

## Calibration

Battery type		float volts (VDC)	boost volts (VDC)
12V	Lead Acid (6 cells)	13.6	14.1
	Ni-Cd (10 cells)	14.1	16.0
24V	Lead Acid (12 Cells)	27.2	28.2
	Ni-Cd (18 Cells)	25.38	28.8
	Ni-Cd (20 Cells)	28.2	32.0

The above are factory standard settings, specials are available on request.

## Dimensions

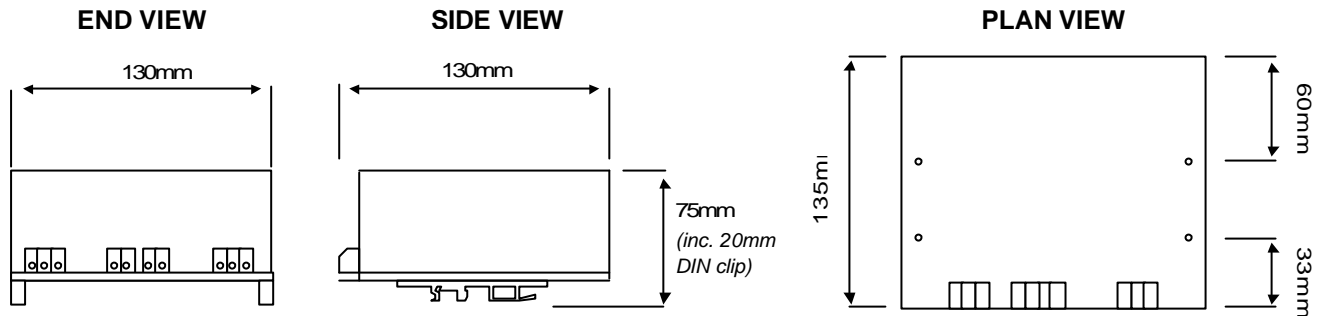

## How to order

When ordering, please specify:-

PRODUCT	Nominal Output VDC				Nominal Output Current			
	12	24	36	48	5	3	2	1.25
SM82125	•				•			
SM82245		•			•			
SM82243		•				•		
SM82362			•				•	
SM82481.25				•				•

INPUT VOLTAGE		
CODE	95-135VAC	195-277VAC
E	•	
F		•

	BATTERY TYPE			
	Lead Acid	10 Cell Ni Cad	18 Cell Ni Cad	20 Cell Ni Cad
LA	•			
10		•		
18			•	
20				•

	OPTIONS			
	Charge Fail	Manual Boost	Spade Connect	Protective Cover
CF	•			
MB		•		
S			•	
PC				•

**Product**      **Input volts**      **Battery type**

The above 3 part number codes must be filled in to complete your order

**SM82125**

**F**

**LA**

**Options**      **Options**      **Options**      **Options**

Insert options when required, if no options are required, leave empty

**CF**

**PC**

The above example shows the order code for a 195-277VAC input, 12V@5A DC output charger calibrated for a vented lead acid battery, and with charge fail and protective cover options.

\*DIN Rail Clips are provided as standard when ordering the SM82 range of battery chargers in a protective cover.

**Computronic Controls Ltd**  
41 - 46 Railway Terrace  
Nechells, Birmingham, B7 5NG  
United Kingdom  
Tel +44 121 327 8500  
Fax +44 121 327 8501  
email: sales@computroniccontrols.com  
web: www.computroniccontrols.com