

SW5 NiCad Charger Automatic Battery Chargers



- **5 different current outputs**
For use with AA, PP9, C, D and F cells
- **Fully automatic charge regulation**
- **Free standing desk top design**
- **Switchable input voltage**
110-120VAC and 220-240VAC
- **Charging indication**

Description

The SW5 is a highly efficient high performance charger with a most versatile performance. Due to its very smooth output (< 1% ripple) the charger is suitable for all types of sealed nicad batteries. The charger provides a constant current output at one of 5 preset values selectable via a 5 position switch. The graphs below show expected charge conditions, the units must be disconnected once end of charge is reached to prevent batteries from overheating.

Charging current vs time

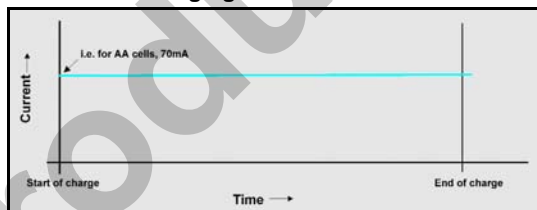

Charging voltage & temperature vs time

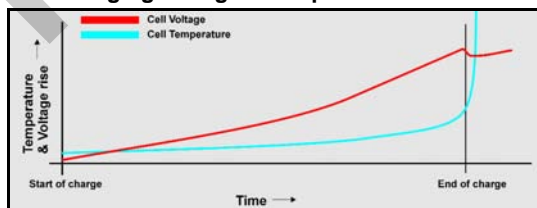

The SW5 provides a switchable output between 70mA and 700mA allowing charging of varied NiCad packs, and the wide input voltage range allows for worldwide application. The free standing desk top unit comes complete with full mains and charging indication and connection is made simple via colour coded screw-in terminals.

Product Specification

Power Supply:

nominal operating voltages	110-120VAC and 220-240VAC (switchable)
nominal operating frequency	50-60Hz

DC Charge Output:

output current ADC	max 700mA
nominal voltage VDC	24V
line regulation	< 1%
load regulation	< 1%
output ripple	< 1%
charging settings	see table overleaf

General:

operating temperature	-10 to +55°C
overall dimensions (w x h x d)	108mm x 90mm x 180mm (4.25" x 3.5" x 7.1")
weight	1.6g (3.52lbs)
EMC emission / immunity	EN 58801-2 / EN50082-2

Warranty

A one year limited warranty on materials and workmanship is given with this product. Details are available upon request.

Electrical connection

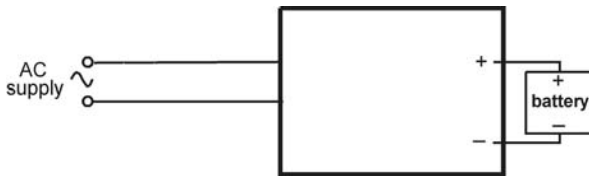

Notes:

Check supply voltage and set switch at rear accordingly. There are two ranges : 110-120VAC and 220-240VAC)

WARNING: Applying a 220-240VAC input to a unit set in the 110-120VAC range can damage to unit.

Calibration

Cell Type	Maximum No. Of Cells	Output mA
AA	16	70
PP9	2	120
C	16	220
D	14	400
F	12	700

The above are factory standard settings, specials are available on request. Only specified type of batteries should be charged with this unit, charging other types of batteries may cause damage and result in serious personal injury.

Dimensions

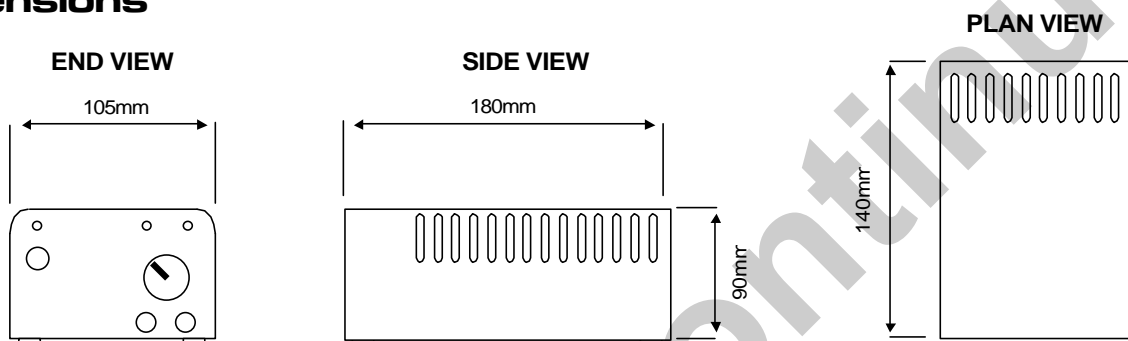

How to order

When ordering, please specify:-

PRODUCT	Nominal Output mA					Nominal Output Voltage
	70	120	220	400	700	24
SW5	•	•	•	•	•	•

INPUT VOLTAGE	
CODE	110-120 / 220-240
EF*	•

* The unit has a slide switch between the two voltage ranges.

BATTERY TYPE	
These chargers are suitable only for NiCd type rechargeable batteries	
NICD	•

Product	Input volts	Battery type
SW5	EF	NICD

The above 3 part number codes must be filled in to complete your order

SW5

EF

NICD

The above example shows the order code for a desk top charger, switchable between 110-120VAC and 220-240VAC input, with a switchable output between 70mA and 700mA @ 24V, calibrated for NiCad battery.

Computronic Controls Ltd
 41 - 46 Railway Terrace
 Nechells. Birmingham, B7 5NG
 United Kingdom
 Tel +44 121 327 8500
 Fax +44 121 327 8501
 email: sales@computroniccontrols.com
 web: www.computroniccontrols.com