

Sentinel Battery Charger OPERATION & MAINTENANCE GUIDE

THIS MANUAL REFERS TO THE FOLLOWING MODELS

SNSUL70 12V 5A
SNSUL140 12V 10A
SNSUL140 24V 5A

SNLUL70 12V 5A
SNLUL140 12V 10A
SNLUL 24V 5A

ESNSUL70 12V 5A
ESNSUL140 12V 10A
ESNSUL140 24V 5A

ESNLUL70 12V 5A
ESNLUL140 12V 10A
ESNLUL 24V 5A

For safe and correct use of the unit read the safety instructions which precede the operating instructions for the above units.



**THIS GUIDE CONTAINS 6 PAGES (including this one) IF ANY PAGES ARE MISSING -
CONTACT THE BATTERY CHARGER SUPPLIER OR MANUFACTURER**

IMPORTANT SAFETY INSTRUCTIONS - SAVE THESE INSTRUCTIONS - SAFETY INSTRUCTIONS

This manual contains important safety and operating instructions for models SNSUL70, SNSUL140, SNLUL70, SNLUL140, ESNSUL70, ESNSUL140, ESNLUL70 and ESNLUL140.

- Do not expose charger to rain or snow
- Use of an attachment not recommended or sold by the battery charger manufacturer may result in risk of fire, electric shock, or injury to persons.
- Do not operate charger if it has received a sharp blow, been dropped, otherwise damaged in any way; return to supplier.
- Do not disassemble charger, return to supplier when service or repair is required. Incorrect reassembly may result in a risk of electric shock or fire.

WARNING - RISK OF EXPLOSIVE GASES

WORKING IN VICINITY OF A LEAD-ACID BATTERY IS DANGEROUS. BATTERIES GENERATE EXPLOSIVE GASES DURING NORMAL BATTERY OPERATION.

To reduce the risk of battery explosion, follow these instructions and those published by battery manufacturers and manufacturer of any equipment you intend to use in vicinity of the battery. Review cautionary marking on these products and on any attached equipment.

PERSONAL PRECAUTIONS

- (i) Someone should be within range of your voice or close enough to come to your aid when you work near a lead-acid battery.
- (ii) Have plenty of fresh water and soap nearby in case battery acid contacts skin, clothing or eyes.
- (iii) Wear complete eye protection and clothing protection. Avoid touching eyes while working near batteries.
- (iv) If battery acid contacts skin or clothing, wash immediately with soap and water. If acid enters eyes, immediately flood eyes with running cold water for at least 10 minutes and get medical attention immediately.
- (v) NEVER smoke or allow a spark or flame in vicinity of battery.
- (vi) Be extra cautious to reduce risk of dropping a metal tool onto battery. It may spark or short-circuit the battery or other electrical part that may cause explosion.
- (vii) Remove personal metal items such as rings, bracelets, necklaces, and watches when working with a lead-acid battery. A lead-acid battery can produce a short-circuit current high enough to weld a ring or the like to metal, causing a severe burn.
- (viii) Use charger only for charging batteries as stated on the charger. Do not use battery charger for charging dry-cell batteries that are commonly used with home appliances. These batteries may burst and cause injury to persons and damage to property.
- (ix) NEVER CHARGE A FROZEN BATTERY

PRIOR TO INSTALLATION / COMMISSIONING

- Clean battery terminals. Be careful to keep corrosion from coming in contact with eyes.
- Add distilled water in each cell until battery acid reaches level specified by battery manufacturer. This helps purge excessive gas from cells. Do not overfill. For a battery without cell caps, carefully follow manufacturer's recharging instructions.
- Study all battery manufacturer's specific precautions such as removing or not removing cell caps while charging and recommended rates of charge.
- Determine voltage of battery by referring to engine manual and ensure matches charger's output voltage.

CHARGER LOCATION AND CONNECTION

- Never place charger directly above battery being charged, gases from battery will corrode and damage charger.
- Never allow battery acid to drip on charger when reading specific gravity or filling battery.
- Do not operate charger in a closed-in area or restrict ventilation in any way.
- The battery charger should be connected to a grounded, metal, permanent wiring system; or an equipment-grounding conductor should be run with circuit conductors not connected to equipment-grounding terminal on battery charger.
- Connections to battery charger should comply with all local codes and ordinances.
- Open Frame Models - These battery chargers should be installed so that they are not likely to be contacted by people.
- Enclosed Models - The AC wiring should be independent of the DC and alarm wiring. Use 2.5mm² (Charger to battery) leads. Use 2.5mm² For input and ground connections.

For safe and correct use of the unit follow the following steps, should you have any problems and the unit does not function as expected consult our troubleshooting guide at the end of these instructions.

- Visually inspect unit for any signs of damage, caused by transport or storage
- Mount charger as outlined above, paying attention to ambient temperature
- Ensure mains supply is isolated and connect observing the correct rated input voltage
- Ensure unit is earthed at the marked earth stud
- Check batteries in accordance with manufacturer guidelines
- Check charger is correct for battery type and voltage
- Connect unit to batteries, observing correct polarity and ensuring a secure and tight connection
- Switch on unit at mains supply

GENERAL INFORMATION (ctd)

Current Limiting

The Sentinel Battery Charger is current limited and will only output the rated current of the charger (see chart below)

SENTINEL CURRENT RATINGS

MODEL	RATING
SNxUL70 & ESNxUL70	5A
SNxUL140 & ESNxUL140 12V	10A
SNxUL140 & ESNxUL140 24V	5A

Battery Charged Condition

When charged the battery will only accept a charge to replace the losses within the battery (approx. 1mA per AH of battery). If there is a standing load (i.e. the panel controller etc) the charger will output the standing load plus the losses to the battery i.e. if a standing load of 1A is present with 50AH Vented Lead Acid batteries then charger will supply 1.05 amps.

A charged battery with open circuit terminals (i.e. no load connected) will always be higher than nominal battery voltage (i.e. 12.6 on a 12V lead acid battery)

Dimensions

figure 1a - Open frame models

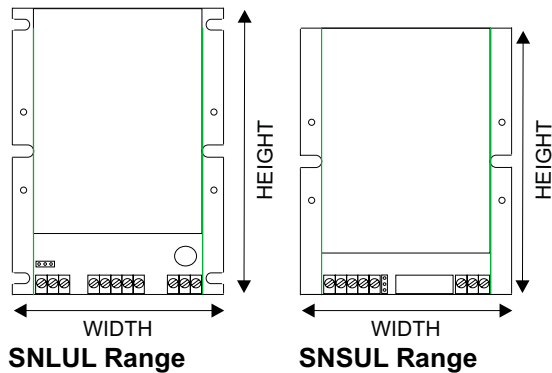

	W	D	H	Weight
SNLUL	105mm 4.1"	70mm 2.75"	150mm 5.9"	0.6Kg 1.3lbs
SNSUL	105mm 4.1"	70mm 2.75"	130mm 5.1"	0.55Kg 1.2lbs

figure 1b - Wall mounted enclosed models

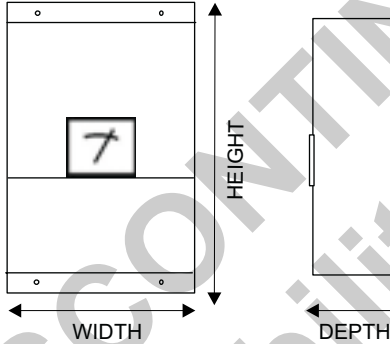

	D	W	H	Weight
ESNLUL	115mm 4.5"	140mm 5.5"	281mm 11.1"	1.6Kg 3.5lbs
ESNSUL	115mm 4.5"	140mm 5.5"	281mm 11.1"	1.6Kg 3.5lbs

IMPORTANT ASSEMBLY INSTRUCTIONS - SAVE THESE INSTRUCTIONS

OPEN FRAME MODELS - SNSUL70, SNSUL140, SNLUL70 & SNLUL140

- The charger must be mounted as shown in Figure 2a, with heatsink fins in vertical position.
- 2 or 4 screws should be used to mount charger to panel. Ensure screws are tightened firmly as as not to become loose during normal use on engine.
- Adequate consideration should be given to ventilation for proper heat dissipation.

WALL MOUNTED ENCLOSURE MODELS - ESNLUL70, ESNLUL140, ESNLUL70 & ESNLUL140

- The charger must be mounted as shown in Figure 2b.
- By unscrewing the fixing screws the faces can be opened on their hinges, to allow access to the internal connections.
- Cable entry is via knock-outs on either side of the unit, these must be carefully removed from the enclosure sides.
- A suitable cable-gland (20mm/0.8" DIA) should be used to prevent damage to cables and stop unwanted entry into inner part of charger. See "Electrical Connection" for details of terminal connections.
- The lower face should be firmly screwed to the charger before use.
- Four screws should be used to mount charger to panel. Ensure screws are tightened firmly as as not to become loose during normal use on engine.
- Adequate consideration should be given to ventilation for proper heat dissipation.

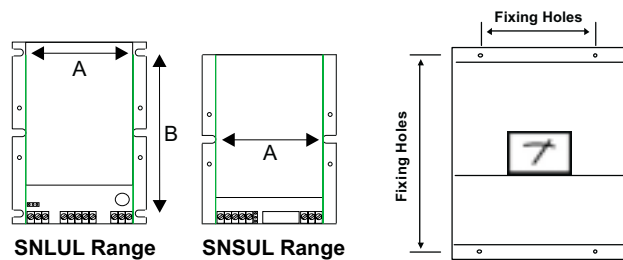

	SNSUL All models (mm)	SNLUL All models (mm)
A	95	95
B		130

Fixing hole dimensions:	
Width (between holes)	- 66mm / 2.6"
Height (between holes)	-274mm / 10.75"
Fixing holes	Ø=6mm (0.2")

Figure 2a - open frame models

Figure 2b - wall mounted enclosure models



CAUTION: When handling chargers, care should be taken not to place excessive strain on either the heatsink, PCB, transformer or connecting wires. Unit should be handled by main heatsink/case (open frame models) or steel enclosure (enclosed models).

IMPORTANT OPERATING INSTRUCTIONS - SAVE THESE INSTRUCTIONS

Before operating the battery charger, ensure that the charger is assembled and installed as per the section listed in these instructions.

Terminal Connection Information

SNLUL70, SNLUL140, ESNLUL70, ESNLUL140

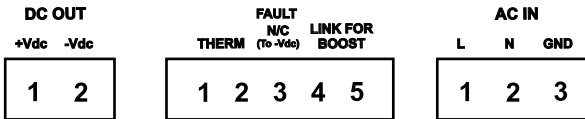

- Output: DC Out (1 + 2) to battery
CAUTION: Observe correct polarity
- Input: AC supply
CAUTION: Observe correct voltage as stated on unit
- ALARM INDICATION - Over Voltage, Under Voltage and Charge Fail**
3 - Change over contact for common alarm signal
(See notes on connection of alarms - see right)
- Boost: 4 + 5 - Boost Initiate - Link these 2 connections to force the charger from into a single boost cycle of operation.
(Once the charger has completed a single boost cycle as outlined on page 3 of these instructions the charger returns to it's normal mode of operation)
- THERM: 1 + 2 - Connect correct stated value of thermistor for monitoring remote battery temperature.

SNSUL70, SNSUL140, ESNSUL70, ESNSUL140



- Output: DC Out (1 + 2) to battery
CAUTION: Observe correct polarity
- Input: AC supply
CAUTION: Observe correct voltage as stated on unit
- ALARM INDICATION - Over Voltage, Under Voltage and Charge Fail**
5 - Change over contact for common alarm signal
(See notes on connection of alarms - see right)
- THERM: 3 + 4 - Connect correct stated value of thermistor for monitoring remote battery temperature.
Thermistor Values
12V Models - 10K Thermistor
24V Models - 20K Thermistor

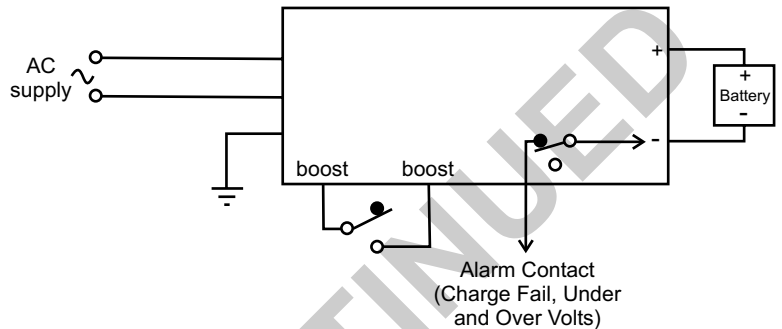

Connection to Mains Supply:

Ensure supply is isolated before connection is made to charging unit
Ensure unit is properly earthed at earth stud (enclosed) on chargers metal chassis
CAUTION: Ensure correct AC voltage is supplied to unit, applying 240VAC on a 120VAC unit will destroy it and could cause serious personal injury.

Connection to Batteries:

Ensure mains supply is isolated before connecting charger to batteries
Ensure battery type and voltage are correct before connecting to batteries
WARNING: Charging either different voltage or type of batteries from stated type may result in damage to both the charging unit and/or batteries and could result in serious personal injury.

Disconnection of Batteries:

Ensure mains supply is isolated before disconnecting charger from batteries
WARNING: Disconnecting the batteries whilst mains supply is connected to the charger could result in a spark at battery terminals, this could ignite the hydrogen given off from the batteries.

Boost Initiate Connection:

The charger will be in it's normal mode of operation whilst the boost link is broken, upon connecting the two *boost initiate* terminals the charger will perform a single auto-boost cycle, whereby the charger outputs a higher voltage, once battery voltage has reached this point, the charger returns to it's normal float mode of operation.

Over Voltage, Under Voltage and Charge Fail Connection (if fitted):

In a de-energised state the COM - N/C contact is alarmed. The relay energises on power up and changes state. The contact is common to -Vdc and rated at 1A @ 30VDC.

Fuses:

All Sentinel models are fitted with mains input fuses at the required ratings (see markings on chargers). Before replacing any fuses, ensure charger is isolated from mains supply.

The Sentinel Range are fitted with a self-resetting polyfuse on the dc output. If reverse polarity or short circuit faults are made, isolate supply, disconnect the outputs and allow fuse to self-reset. The charger can then be re-connected and switched back on. No replacement of output fuse should be necessary. If fuse fails to reset, the charger should be returned to supplier. Ensure correct rating when replacing input fuses.

AUTOMATIC BATTERY CHARGER

The Sentinel-L (SNL and ESNL) range are automatic battery chargers, if voltage falls below a preset voltage (12.2V on a 12V lead-acid battery) they automatically enter an increased charging voltage state (boost). Once the batteries have reached this point, the charger will switch to it's normal "float" voltage. this prevents over-charge, which in turn prevents the battery from over-gassing and subsequently maximises battery life.

WARNING: The Sentinel range is not USER SERVICEABLE. No attempt should be made to replace or repair the charger, any attempt to do so may invalidate any warranties and could cause serious personal harm or injury as well as damage to both the battery charger and any connected devices. In event of failure the charger should be returned to supplier.

ELECTRICAL CONNECTION



WARNING: DANGER OF INJURY OR DEATH. Before connection, disconnection or handling of SENTINEL battery charger, ensure that all AC power supplies are isolated. Connection to or disconnection from live wiring can also cause damage to internal components.

TROUBLESHOOTING FLOWCHART

