

Enclosed Monitor Range of Automatic Battery Chargers



- **Heavy duty float charging:**
9A, 15A or 30A @ 24V - 16A, 30A or 60A @ 12V
- **DC ammeter**
- **Lead Acid or Ni-Cd calibrations**
- **Optional boost mode**
- **Optional charge fail relay output**
- **Wall or floor mounted metal enclosure**

Description

The enclosed Monitor range provides fully automatic, heavy duty, thyristor controlled, charging of vented lead acid or NiCd batteries. The units may be used in a wide range of industrial charging applications, including standby engines, pumps, generators and cyclic battery charging.

The control circuit ensures that charger maintains the battery voltage at the pre-calibrated float level, while supplying any additional load current up to the specified maximum.

The charger is housed in a vented metal enclosure and can be wall mounted or free standing.

The chargers can be equipped with charge fail and boost options. Enclosures are fitted with an ammeter, MCB, charge fail LED and charging LED.

Boost option

A 'boost' mode of operation provides increased voltage output. Selection of the boost mode is via three terminals, allowing activation by a time delay relay or switch. A calibration table overleaf shows details of float and boost voltages.

Charge fail option

A self diagnostic 'charge fail' circuit and relay output can be provided. The volt free relay de-energises in the event of a charging fault or loss of AC input.

Product Specification

Power Supply:

nominal operating voltages	110/120/125/135 VAC (110V Units) 220/240/250/270 VAC (240V Units)
permissible voltage variation	± 6% of nominal
nominal operating frequency	50/60Hz

DC Charge Output:

maximum current ADC	15	30
nominal voltage VDC	24	12
float / boost voltages	see table over leaf	

Charge Fail Output:

relay type	volt free SPDT contacts relay de-energised on fault
contact rating	1A @ 30VDC (resistive load)

General:

operating temperature	-10 to +55°C
overall dimensions	see table over leaf
weight	see table over leaf
EMC emission / immunity	EN 58801-2 / EN50082-2

Warranty

A one year limited warranty on materials and workmanship is given with this product. Details are available upon request.

Electrical connection

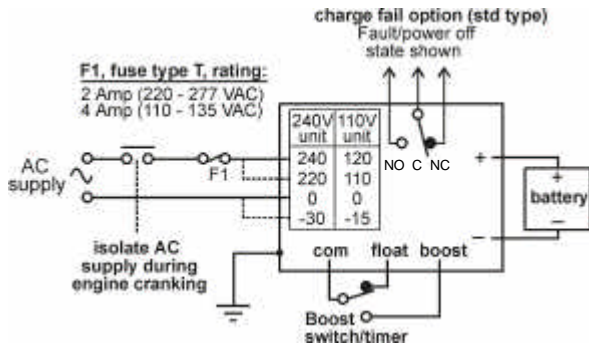

Notes:

- 1) battery output is isolated from chassis
- 2) chassis must be connected to a low impedance earth

Calibration

Battery type*		float volts (VDC)	boost volts (VDC)
12V	Lead Acid (6 cells)	13.6	14.1
	Ni-Cd (10 cells)	14.1	16.0
24V	Lead Acid (12 Cells)	27.2	28.2
	Ni-Cd (18 Cells)	25.38	28.8
	Ni-Cd (20 Cells)	28.2	32.0

*Note: the monitor range is designed for use with vented batteries only. These chargers are NOT suitable for valve regulated lead acid (VRLA) or sealed type cells. For charging non vented chargers see the switch mode range.

If in doubt, contact our technical department .

Dimensions

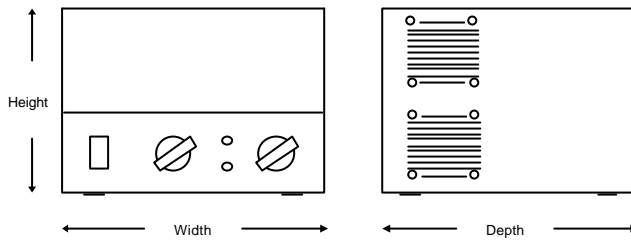

Wall mounting dimensions: 2 holes ($\varnothing=8\text{mm}$) at 33mm in from side edges of unit, 33mm down from top edge, and 2 holes ($\varnothing=8\text{mm}$) at 33mm in from side edges of unit, 50mm up from bottom edge.

	Depth (mm)	Width (mm)	Height (mm)	Weight
EM200	260 (10.2")	260 (10.2")	220 (8.7")	7Kg (15.54lbs)
EM360	260 (10.2")	260 (10.2")	220 (8.7")	9Kg (19.98lbs)
EM720	365 (14.2")	455 (18")	210 (8.3")	18Kg (39.96lbs)

How to order

When ordering, please specify:-

PRODUCT	Nominal Output VDC		Nominal Output Current				
	12	24	9	15	16	30	60
EM200249		•	•				
EM3602415		•		•			
EM2001216	•				•		
EM3601230	•					•	
EM7202430		•				•	
EM7201260	•						•

INPUT VOLTAGE		
CODE	110VAC	230VAC
C	•	
D		•

	BATTERY TYPE			
	Lead Acid	10 Cell Ni Cad	18 Cell Ni Cad	20 Cell Ni Cad
LA	•			
10		•		
18			•	
20				•

	OPTIONS	
	Charge Fail	Manual Boost
CF	•	
MB		•

Product **Input volts** **Battery type**

Options **Options**

The above part number codes must be filled in to complete your order

Insert options when required, if no options are required, leave empty

EM200249

D

LA

CF

MB

The above example shows the order code for an enclosed 240VAC input, 24V@9A,DC charger, calibrated for a vented lead acid battery, and with the charge fail and manual boost options.

Computronic Controls Ltd
 41 - 46 Railway Terrace
 Nechells. Birmingham, B7 5NG
 United Kingdom
 Tel +44 121 327 8500
 Fax +44 121 327 8501
 email: sales@computroniccontrols.com
 web: www.computroniccontrols.com