

Guardian series, enclosed UL/CSA Approved Automatic Battery Chargers



Description

The Guardian is a highly efficient, high performance battery charger. The output is configured for accurate fast charging, optimum battery life and reliability. High impedance transformer technology gives a low ripple output (<1%) suitable for charging either sealed or vented batteries, e.g. Nickel Cadmium (NiCd), sealed lead acid (VRLA), vented and Plante cells. The enclosed Guardian range can be used in a wide range of industrial charging applications, including standby engines, pumps and generators.

Each charger consists of a transformer, rectifier and control circuit in a metal wall-mounted enclosure with DC ammeter and voltmeter. The control circuit ensures that the charger maintains the battery voltage at the pre-calibrated float level, while supplying any additional load current up to the specified maximum.

Auto Boost (equalising) operation

Auto boost operation provides a temporary increase in output voltage, equalising the battery charge between cells and maximising battery life and capacity. Auto boost is triggered automatically when the battery falls below a preset voltage. Once the batteries have reached the boost voltage level, Guardian reverts to its normal float charge mode, preventing battery over-charge and gassing.

Autoboost can also be manually initiated by linking two 'boost' terminals, e.g. via a panel switch or push-button.

Temperature compensation & RTC option

The optimum charge voltage for lead acid and NiCd batteries varies with ambient temperature. All Guardian chargers can be configured (using circuit board links) with automatic output temperature compensation, either by on-board sensor, or by RTC option remote sensor with 3m lead.

When temperature compensation is enabled, output voltage decreases as ambient temperature increases at a rate of 3mV/°C/cell (see calibration table overleaf).

-  Approvals
- **Heavy duty float charging:**
10A or 20A @ 12 VDC or 24VDC
- **Lead acid or NiCd batteries**
- **Auto boost operation**
- **Temperature compensation**
- **NFPA 110 alarm outputs:**
charge fail, under volts & over volts
- **Wall mounted stainless steel enclosure with DC meters**

Product specifications

power supply:	
operating voltages	110 – 120 VAC ±6% or 230 VAC ±10% (specify)
operating frequency	50 or 60 Hz (specify)
DC charge output:	
output current	10 or 20 A DC
nominal voltage	12 or 24 V DC
voltage ripple	< 1%
float / boost voltages	see table overleaf
'A' option outputs:	
charge fail, low volts & high volts relays	SPDT volt free contacts
contact rating	1A @ 30 V DC (resistive load)
general:	
operating temperature	-10 to +55°C
dimensions	see table overleaf
weight	see table overleaf
EMC emission / immunity	EN61000-6-4 / EN61000-6-2

Alarm outputs

The Guardian provides 3 x NFPA110 compliant alarm relay outputs: battery low volts and battery high volts (both with 120 sec delay) and charge fail.

Installation and connection

Wall or surface-mounting is via slots/holes in the metal enclosure. Connection to panel wiring is by spring clamp terminals, via access holes in the enclosure side. AC supply input and DC charge output are protected with circuit-board mounted fusing.

Please see installation and operation instructions for full details.

Warranty

A two year limited warranty on materials and workmanship is given with this product. Details are available on request.

Electrical connection

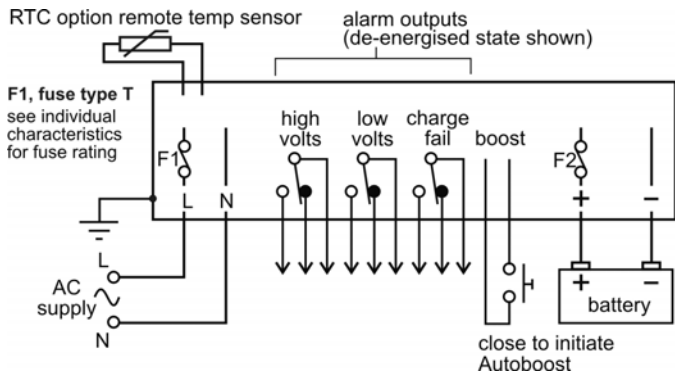

Note: battery output is isolated from chassis.

Output calibration

Calibration figures at 20 deg C. Temperature compensation, if enabled, causes output voltage to automatically decrease (or increase) at a rate of 3mV per cell, per °C increase (or decrease) in temperature.

Battery type		float volts (V DC)	boost volts (V DC)
12V	Vented lead acid (6 cells)	13.5	14.1
	Calcium-Calcium (6 cells)	13.8	15.6
	VRLA, AGM (6 cells)	13.5	14.4
	VRLA, Gel (6 cells)	13.5	13.8
	NiCd (10 cells)	14.1	14.5
24V	Vented Lead acid (12 cells)	27.0	28.2
	Calcium-Calcium (12 cells)	27.6	31.2
	VRLA, AGM (12 cells)	27.0	28.8
	VRLA, Gel (12 cells)	27.0	27.6
	NiCd (18 cells)	25.6	26.1
	NiCd (20 cells)	28.2	29.0

Dimensions

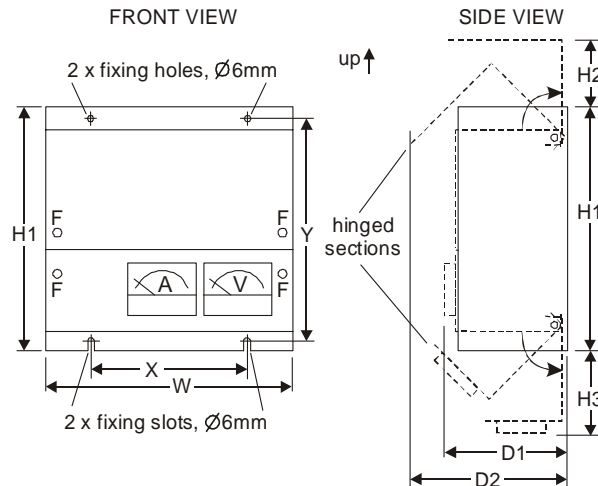

	EG150, EG300 series	EG600 series
Overall:-		
W	275mm / 10.83"	335mm / 13.19"
H1	280mm / 11.02"	310mm / 12.20"
H2	75mm / 2.95"	85mm / 3.35"
H3	90mm / 3.54"	100mm / 3.94"
D1	125mm / 4.92"	145mm / 5.71"
D2	190mm / 7.48"	210mm / 8.27"
Fixing holes:-		
X	172mm / 6.77"	223mm / 8.78"
Y	255mm / 10.04"	285mm / 11.22"
Weight	10.0 Kg / 22.0 lb	17.5 Kg / 38.5 lb

For safe heat dissipation, mount product in orientation shown, with minimum air-gap clearance of 40mm above/below and 25mm at sides.

How to order

When ordering, please specify:-

Product	Nominal Output Voltage, V DC		Max. Output Current, A DC	
	12	24	10	20
EG1501210	●		●	
EG3002410		●	●	
EG3001220	●			●
EG6002420		●		●

Code	Input voltage	
	120 VAC	240 VAC
C	●	
D		●

Code	Input frequency ⁽¹⁾	
	50 Hz	60 Hz
5	●	
6		●

Code	Battery type						
	Vented L/Acid	Vented L/Acid (Ca/Ca)	AGM L/Acid	Gel L/Acid	10 cell NiCd	18 cell NiCd	20 cell NiCd
LA	●						
CA		●					
AGM			●				
GEL				●			
10NC					●		
18NC						●	
20NC							●

Code	Options
RTC	Remote temp. compensation (incl. sensor + 3 metre lead) ●

product	input volts	input frequency	battery type	option
e.g. EG3001220	D	5	LA	RTC

The above 4 part number codes must be used

e.g. EG3001220 D 5 LA

The above example shows the order code for a 12V/20A charger, with 240VAC/50Hz input and output calibrated for vented lead acid batteries, plus remote temperature compensation

Insert option code if required

RTC

Guardian is also available in an open-frame version – see separate datasheet for details.